

SHEARER CLEARER

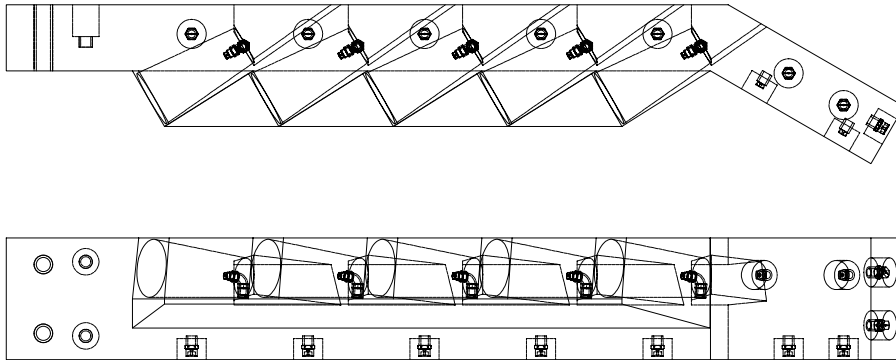

WWW.VLI.COM.AU

VLI SHEARER CLEARER

VLI Shearer Clearers are a solid FRAS polyurethane unit designed to withstand the rigors of longwall mining. The units come in left & right hand configuration with multiple water and venturi water sprays.



MODELS AVAILABLE

Model	PSC1000	PSC1600	PSC2000
			
Width (mm)	1000	1600	2000
Height (mm)	120	230	230
Total Number of Sprays	8	16	20
Face	4	5 + 2	7 + 2
Bottom	4	5 + 2	6 + 3
End	-	2	2
Handed	Left and Right handed models available		
Through Mount Hole	1 x 27mm	2 x 27mm	2 x 27mm
Water Consumption (l/min)			
@ 0.4 Bar	25	42	44
@ 1.5 Bar	47	79	84

GET IN TOUCH

NEW SOUTH WALES

UNANDERRA
3 Investigator Drive
Unanderra NSW 2526
T +612 4220 9400

BERESFIELD
8 Balook Drive
Beresfield NSW 2322
T + 612 4964 2300

QUEENSLAND

MACKAY
6 Fursden Street
Glenella QLD 4740
T +617 4942 7495

EMERALD
44 Industrial Drive
Emerald QLD 4720
T +617 4987 5011

BRISBANE
Building 3, 836 Boundary Road
Coopers Plains QLD 4108
T +617 3276 7000

WESTERN AUSTRALIA

PERTH
5 Temperley Close
Welshpool WA 6106
T +618 9452 6600

KALGOORLIE
2 Brooks Way
Kalgoorlie WA 6430
T +618 9021 2102

SALES@VLI.COM.AU
VLI.COM.AU